



PHOTO-EYE SET INSTALLATION MANUAL

Part # PHOTOEYESET0001

PHOTOEYESET0002

TABLE OF CONTENTS

List of Contents.....	Page: 1
Tools and Materials.....	Page: 1
Conveyorized System Install.....	Page: 1
Non-Conveyorized System Install.....	Page: 3
Electrical Installation.....	Page: 4
Window Photo-Eye.....	Page: 5
Support Documents.....	Page: 6

Equipment Specifications and Requirements

Physical:	Tunnel Footprint	12"	Utilities:	Supply Voltage Emitter-Receiver	24-250VAC/DC
	Stand Max Height	33"		Supply Voltage Window	120VAC
	Range	60m		Output Rating	5A (max) @ 250VAC (max) 150W (max) @ 30VDC (max)

List of Contents

- 2 - Photo-Eye Stands (1-Tall, 1-Short)..... Pic #1
- 1 - Photo-Eye Set (Emitter and Receiver)..... Pic #2
- 1 - Accessory Bag..... Not Shown



Pic #1: Photo-Eye Stands (w/o junction boxes)

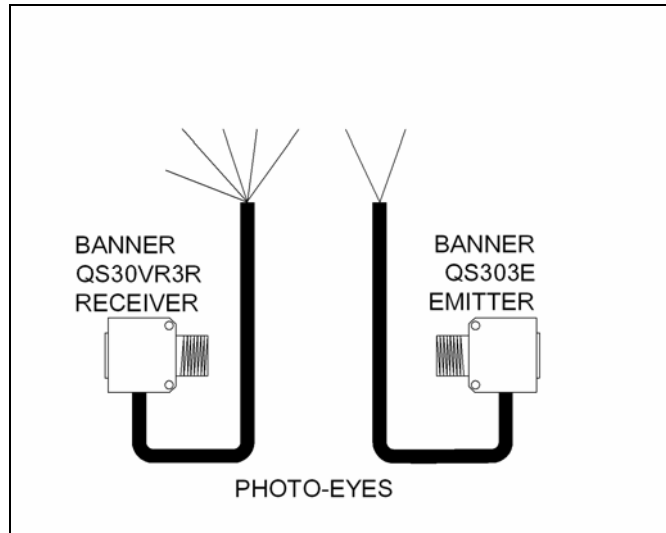

Pic #2: Photo-Eye Set

Suggested Installation Tools and Materials

- Hammer Drill with 1/2" Drill bit
- Sledge Hammer
- 1/2" Open Wrench
- (8) Wedge Anchor Bolts 1/2" x 3 3/4"
- Torpedo Level

Instruction for Floor Mounted Photo-Eye Set in Conveyorized System

- Open** the box and verify that you have all the required components and your installation material.
- Locate** the area where the MCWW Photo-Eye will be installed and make sure there is sufficient floor space available for the system. The Photo-Eye Set requires an area (**Envelope**) of about 12" off the wash bay line floor.
- Screw** each photo-eye into each swivel mount as shown in picture #3.

- Secure the photo-eye swivel mount to each guard (see Picture #4) using the 1/4"-20 X 1" hex bolt and nuts supplied in the accessory bag.

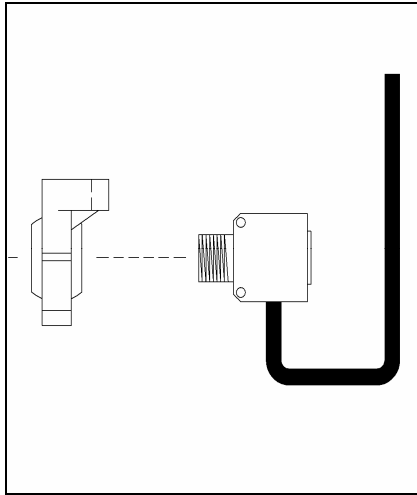

Pic #3: Photo-Eye Mount

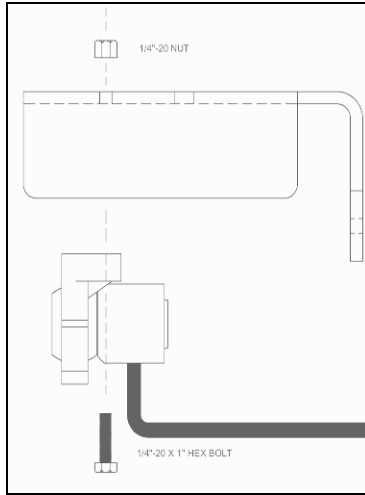

Pic #4: Photo-Eye Guard

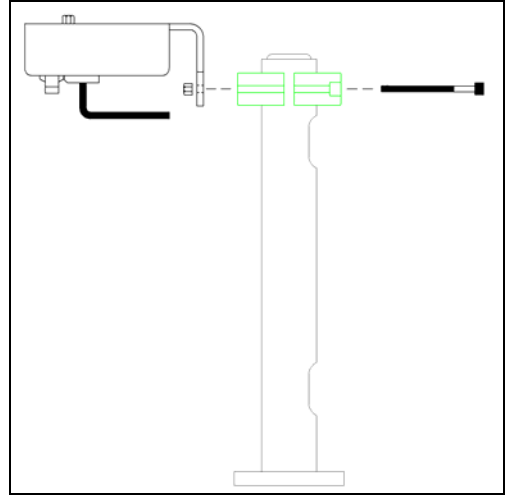

Pic #5: Photo-Eye Stand

- Mount the photo-eye assemblies to each stand with the clamp about 1/2" from the top of the stand as shown in picture #5. Two different stands are provided as a set: One short and one taller. The taller stand is assembled with a short stand and an extension connected together with two half clamps. The different height between the two photo-eye stands allows for a better consistency in detecting the front of different size vehicles.
- Locate the photo-eye stand assembly with the RECEIVER photo-eye (the receiver photo-eye has the cord with 5 wires. The emitter has only two wires) and position it on the mechanical room side of the wash bay, the RECEIVER photo-eye requires more field wiring than the emitter. Position the passenger side photo-eye assembly 96" from the inside edge of the inside conveyor guide rail to the front of the base stand as shown in Picture #6. Install the driver's side unit 42" from the inside edge of the inside conveyor guide rail to the front of the base plate. Finally, off-set the two photo-eye units about 6" apart. The two photo-eye positions being different from the arch will allow a sufficient "off-set" to avoid reading thru open frame vehicle profiles (like the gap between the cabin and the box of a pick-up truck).

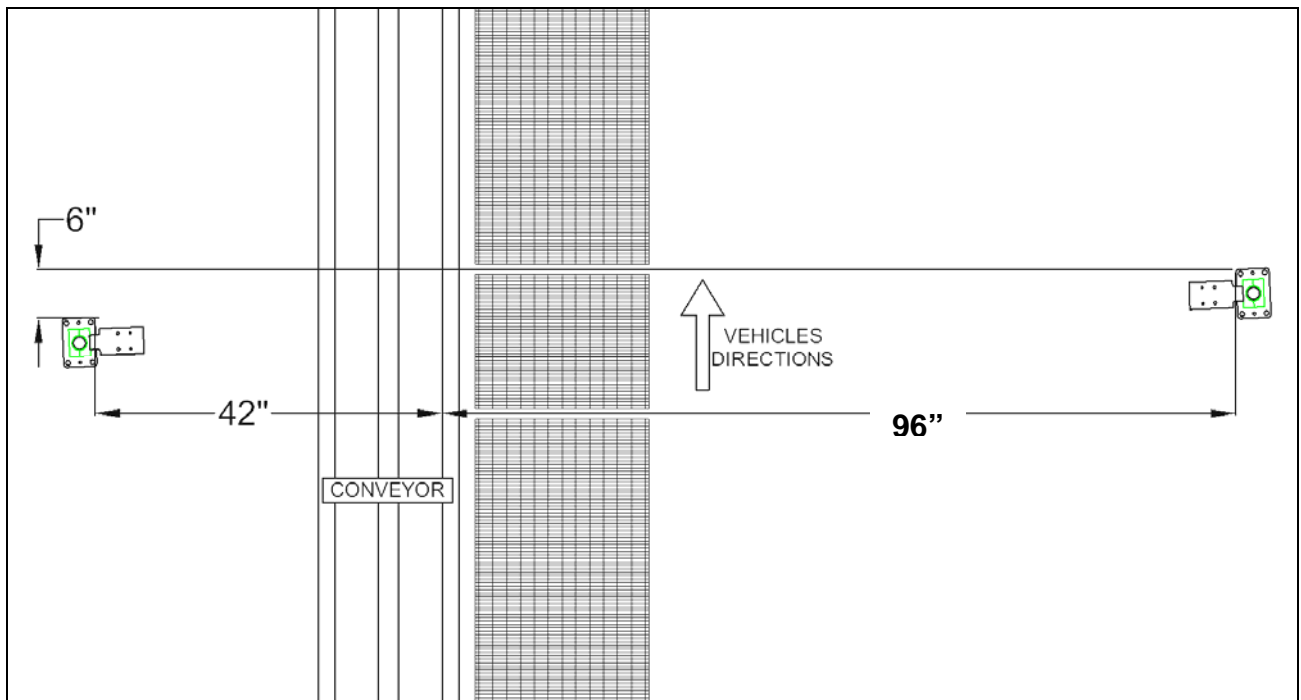

Pic #6: Photo-Eye Installation

- Secure** to the floor both photo-eye bases with ONE ANCHOR each. Now rotate each photo-eye assembly until each photo-eye is lined up directly with each other as shown below. Secure both photo-eyes with a second anchor.

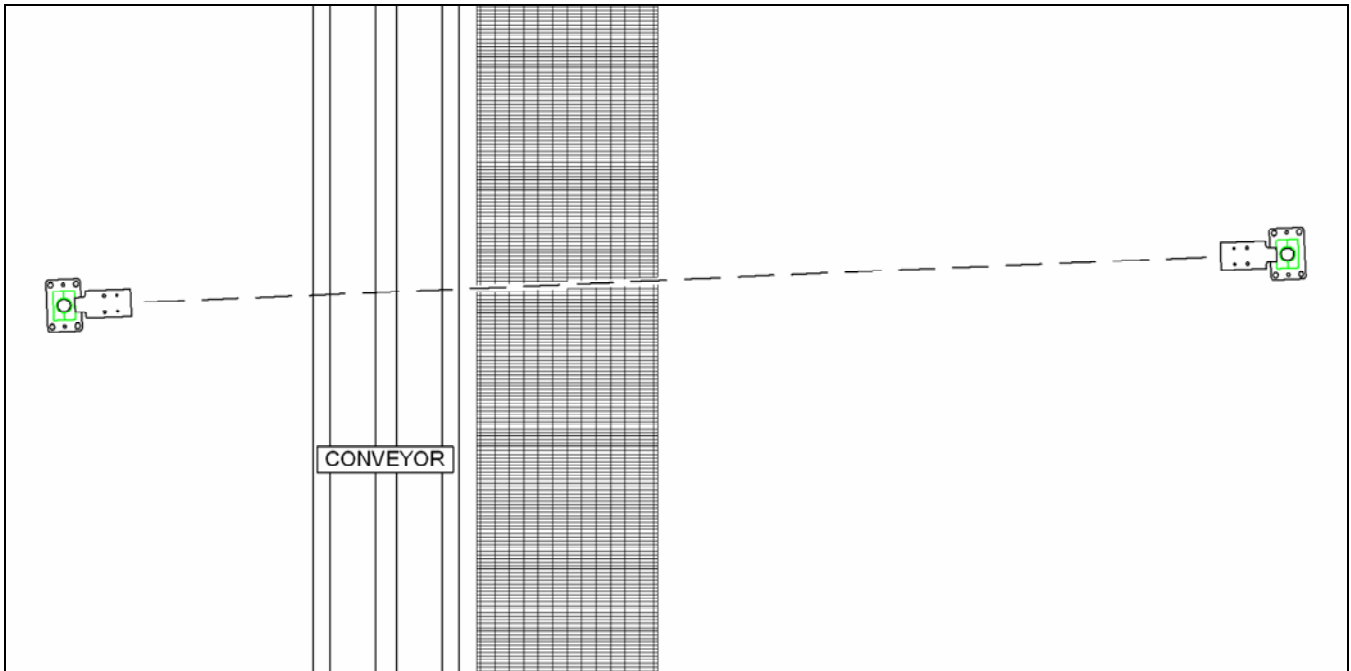

Pic #7: Photo-Eyes in Line

Instruction for Floor Mounted Photo-Eye Set (Other than ConveyORIZED Systems)

- If** you are installing the photo-eyes in a wash bay without a conveyor or specific guide rails, position each photo-eye assembly **140"** between each of them, centered in the wash bay and **6"** OFF SET as explained previously.
- You** may also mount the photo-eye assembly on a wall (see Picture #8). By removing the stand and using only the PHOTO-EYE GUARD assembly, you may secure the photo-eye assembly directly to a wall (see Picture #8). Install with the driver's side photo-eye assembly at least 15" off the floor while the passenger's side has to be 15" higher than the driver's side unit. Keep also **6"** off-set between each photo-eye!
- The** photo-eye stand can also be mounted across a garage door, mounted on the door wall as shown in Picture #9. Use the same measurements described previously for the wall mount application.

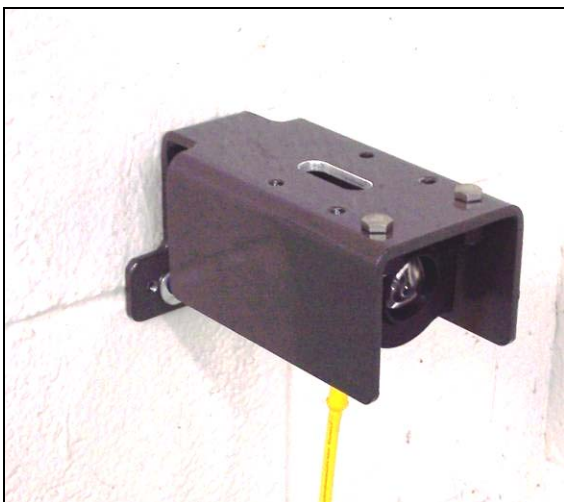

Pic #8: Photo-Eye Guard Wall Mounted

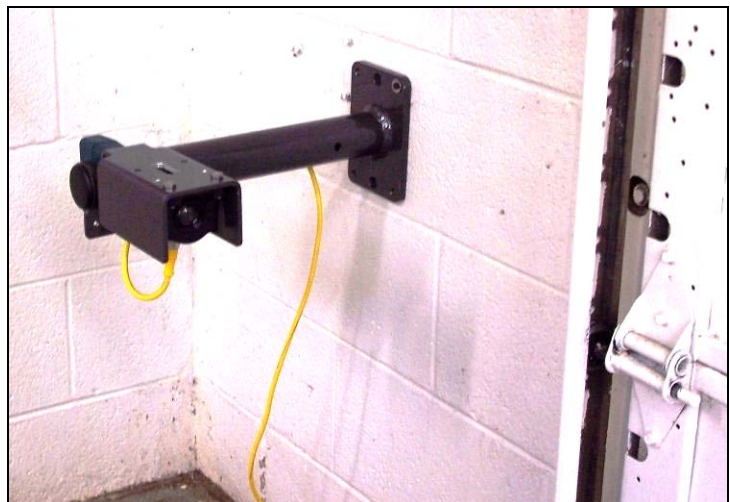

Pic #9: Exit Wall Mounting

Electrical Installation

-  **Any** electrical installation has to be performed by a qualified electrical contractor. Follow all Local, State and National Codes.



WARNING! PROTECT EACH ELECTRICAL CIRCUIT USED FOR THE PHOTO-EYE SYSTEM WITH GROUND FAULT CIRCUIT INTERRUPTOR (GFCI).

- Your** MCWW PHOTO-EYE set is a UNIVERSAL PHOTO-EYE SYSTEM. It allows the installer to use practically any voltage between 24 to 250 VOLTS AC or DC for the supply. The output photo-eye uses a relay with COMMON, NORMALY CLOSE and NORMALY OPEN CONTACTS which can switch also a wide range of voltage up to 30 VDC and 250VAC at 5 AMPS.
- The** photo-eye has a LIGHT ON signal receiver. A LIGHT ON receiver will change the state of its output only when the light from the emitter is received by the receiver. The output is therefore ON only when the beam between the two photo-eyes is NOT interrupted. When the beam of light between the two photo-eyes is broken or interrupted, the receiver output turns OFF. The LIGHT ON feature allows the user to notice when the photo-eye system doesn't work in the event of a failure of the emitter, the receiver, or simply a misalignment of one of the two photo-eyes.



STOP! THE CIRCUIT WHICH IS USED TO SWITCH THE LOAD ON THE OUTPUT SIDE OF THE PHOTO-EYE HAS TO BE PROTECTED TO A MAXIMUM OF 5 AMPS. FAILURE TO DO SO MAY DAMAGE YOUR EQUIPMENT AND/OR VOID THE WARRANTY FROM THE PHOTO-EYE MANUFACTURER!

- Use** the electrical schematic shown in Picture #10 for car wash applications.

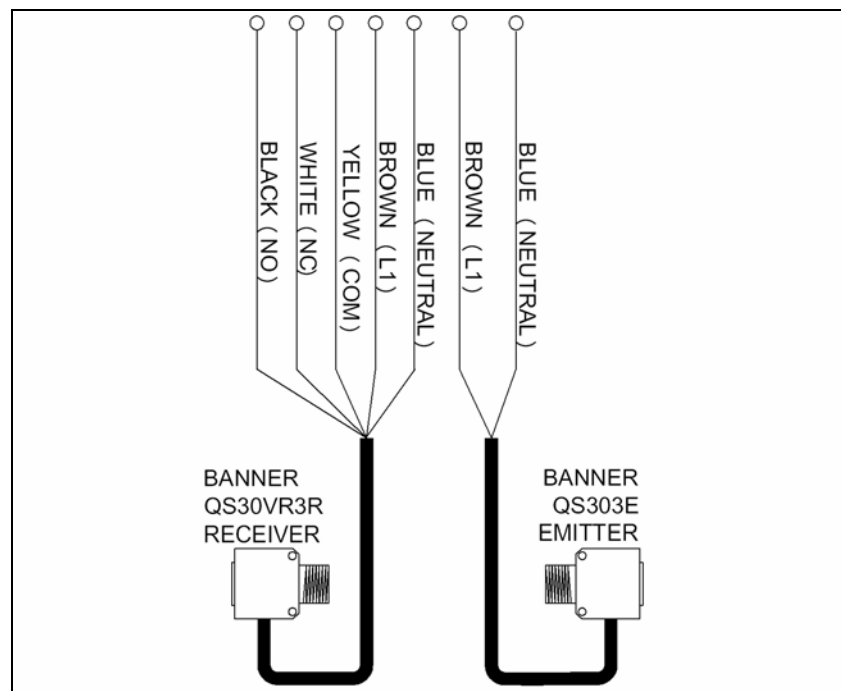

Pic #10: Photo-Eye Electrical Schematic

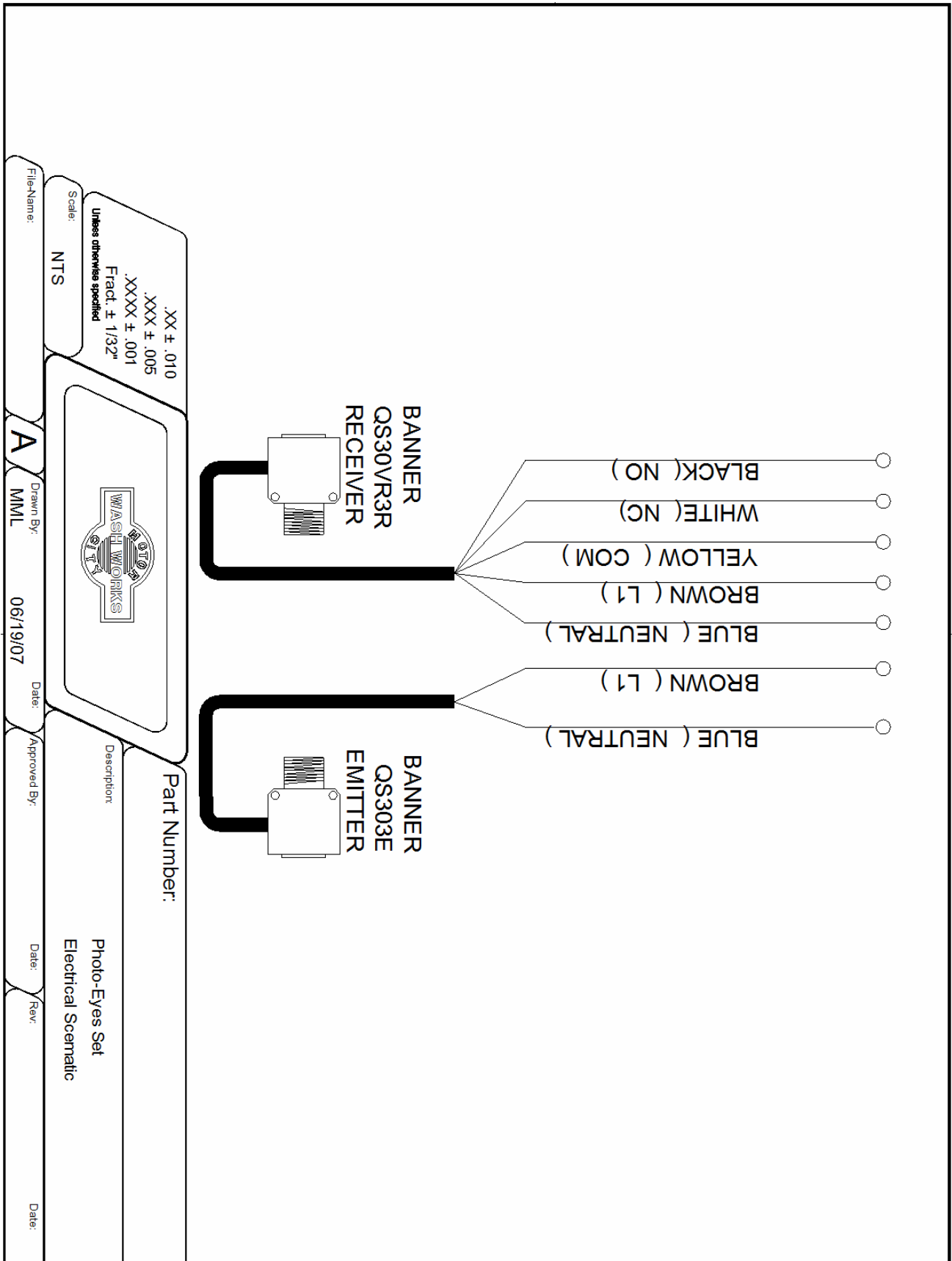

Warranty and Return Procedure

Motor City Wash Works warrants this product to be free of defect in material and/or workmanship for a period of **one year** from the date of purchase. During the warranty period MCWW will at its discretion, at no charge to the customer, repair or replace this product if found defective, with a new or refurbished unit, not to include costs of removal or installation. Any product returned to MCWW for warranty has to have a **Return Material Authorization Number**. All shipping costs to MCWW are assumed by the customer. This is only a summary of **MCWW's Limited Warranty**. Please, communicate with MCWW for our complete warranty.

Prior to returning any product to MCWW, the customer must call in for a **Return Material Authorization Number** and a copy of our **Return Material Authorization Form** must be completed. The **RMA** number must be written clearly on the outside of the shipping package and a copy of the form must be included in the package.